

www.butkus.us



MINOLTA

Freedom 50/FS-35

E INSTRUCTION MANUAL

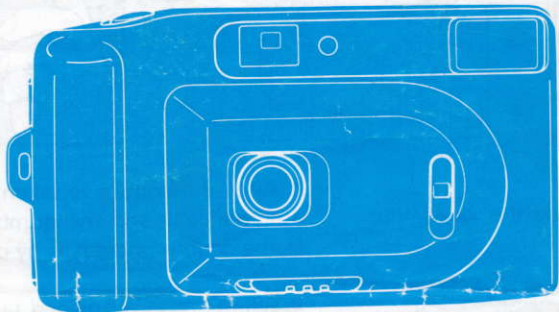

1. MAIN FEATURES

Your Minolta Freedom 50/FS-35 is a compact 35mm camera offering many advanced features to simplify operation and improve picture quality:

- Focus-free operation
- Built-in flash
- Automatic film advance
- Auto DX-code setting

To learn how to operate your new camera properly and obtain satisfying results right from the start, please read the following instructions and cautions carefully before taking pictures.

If you have any questions about this camera, contact your local camera dealer or the Minolta distributor or subsidiary in your area.

2. STRAP

www.butkus.us

Attach strap as shown.

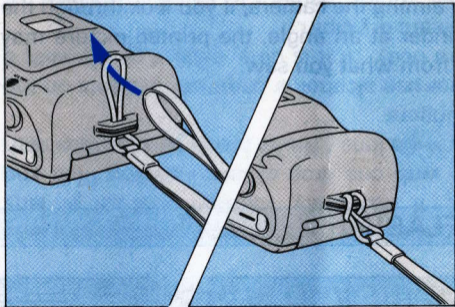

3. NAMES OF PARTS

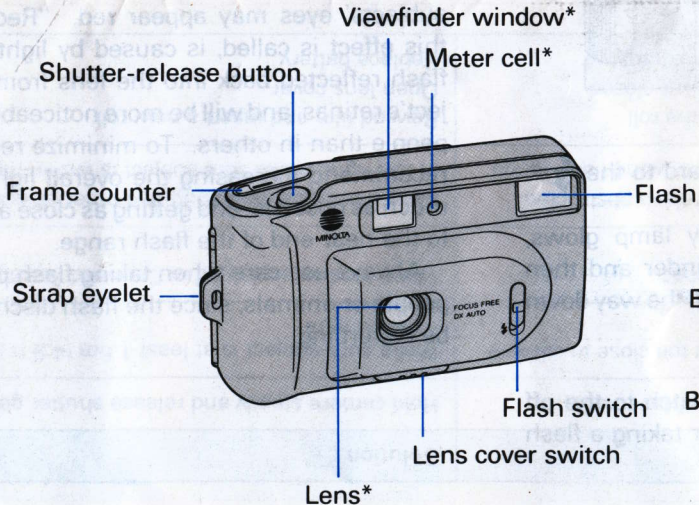



This manual is for reference and historical purposes, all rights reserved.

This page is copyright© by M. Butkus, NJ.

This page may not be sold or distributed without the expressed permission of the producer
I have no connection with any camera company

On-line camera manual library

This is the full text and images from the manual. This may take 3 full minutes for the PDF file to download.

If you find this manual useful, how about a donation of \$3 to: M. Butkus, 29 Lake Ave., High Bridge, NJ 08829-1701 and send your e-mail address so I can thank you. Most other places would charge you \$7.50 for a electronic copy or \$18.00 for a hard to read Xerox copy.

This will allow me to continue to buy new manuals and pay their shipping costs.

It'll make you feel better, won't it?

**If you use Pay Pal or wish to use your credit card,
click on the secure site on my main page.**

PayPal Name Lynn@butkus.org

Venmo @mike-butkus-camera Ph. 2083

www.PayPal.me/lynnbutkus

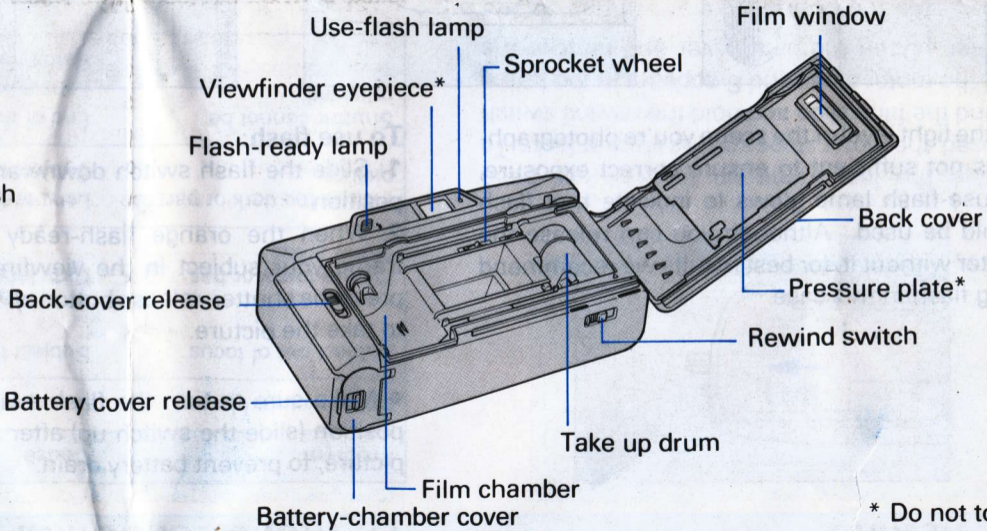

* Do not touch

4. POWER

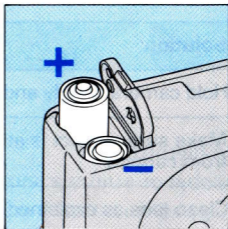
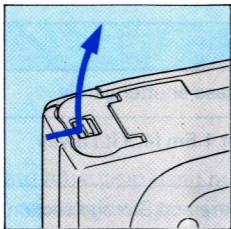

Your Minolta Freedom 50/FS-35 is powered by two AA-size alkaline or carbon-zinc batteries. To load the batteries, open the battery-chamber cover as shown, and insert the batteries as indicated on the inside of the battery cover. Then, snap the cover shut.

- Do not use nickel-cadmium batteries.

BATTERY CAUTIONS

- Keep batteries away from children
- Keep battery contacts clean
- Do not mix batteries of different types, brands or ages

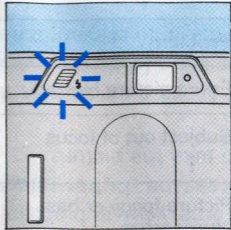
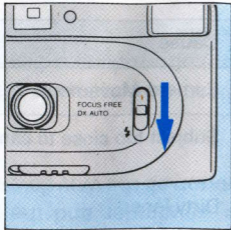

To check battery condition: Move the flash switch to the ⚡ position. When a battery with sufficient power is installed, the flash-ready lamp glows within several seconds. If the flash-ready lamp doesn't glow, check that the battery is inserted correctly. If the battery is correctly inserted and the flash-ready lamp does not glow, or takes longer than 30 seconds to glow, replace it with a fresh one.

5. FILM

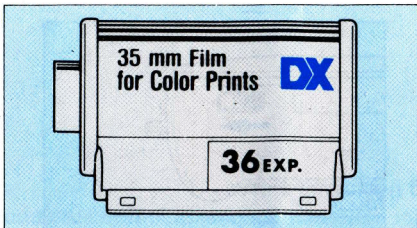

Only 35mm film can be used in this camera. Use of ISO 100 or 400 DX-coded (**DX** is printed on the cartridge) negative film is recommended.

- If you use film that is not DX-coded, the film speed will be set to ISO 100. 72-exposure cartridges and Polaroid instant 35mm films cannot be used.
- Load film in subdued light, or at least shaded from direct sunlight.

6. HOW TO LOAD FILM

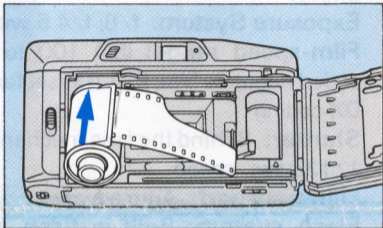
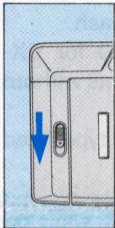

1. Before opening the back cover, make sure the frame counter is at **S**. Open the back cover by sliding the back-cover release in the direction shown.
2. Insert the film cartridge into the film chamber as shown.

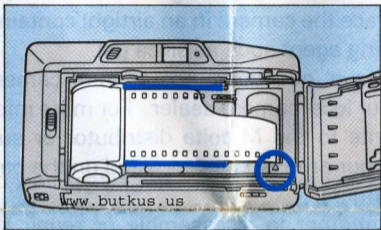

3. Extend the tip of the film over the take-up drum to the film loading indicator, aligning the holes on the top of the film with the teeth on the sprocket wheel as you do so. If the film extends too far, gently slide excess back into the film cartridge.

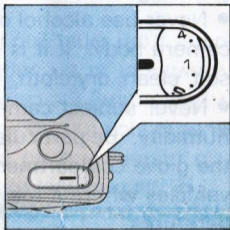
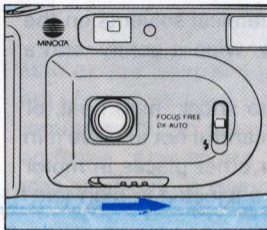

4. Close the back cover.
5. Open the lens cover fully by sliding the lens cover switch, then press the shutter-release button. Press the shutter repeatedly until **1** appears in the frame counter. If the film does not advance, open the back cover, remove the film and reload.

7. HOLDING THE CAMERA

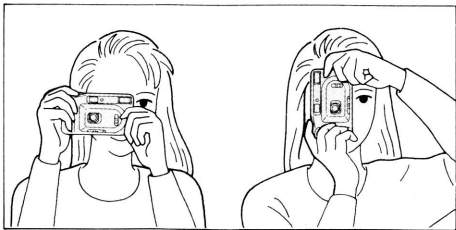

For greatest stability when taking pictures, hold the camera as shown here. Make sure that the lens, flash, and meter cell are not obstructed by your hands, the camera strap, or otherwise. For vertically-framed pictures, hold the camera so that the flash is on top.

For best results, your subject should be at least 1.5 meters (4.9 ft.) from the camera. Also, be sure to look through the center of the viewfinder when aiming the camera; if you look through the viewfinder at an angle, the printed picture may differ from what you saw.

8. TAKING PICTURES

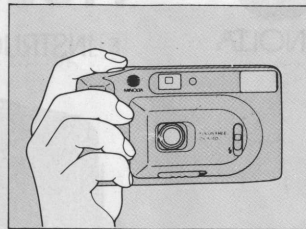
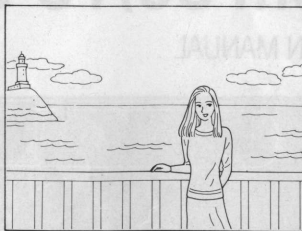
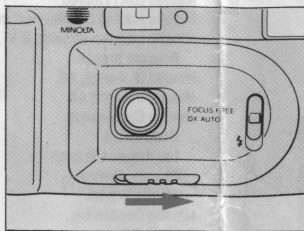

1. Open the lens cover.
2. Compose your subject inside the viewfinder frame.
3. Release the shutter.

If the use-flash lamp glows when you press the shutter-release button, flash should be used to ensure correct exposure. (See **FLASH** section.)

After the picture is taken, the film advances automatically and the number displayed in the frame counter increases by one.

- When you are finished taking pictures, close the lens cover to protect the lens and prevent accidental exposure.

9. FLASH

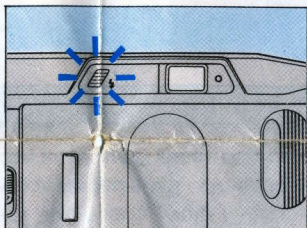
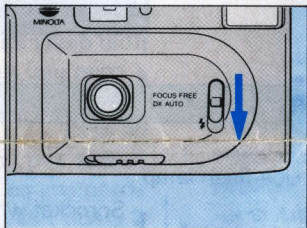
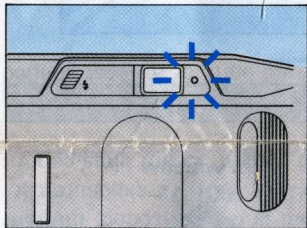

If the light level of the scene you're photographing is not sufficient to ensure correct exposure, the use-flash lamp glows to indicate that flash should be used. Although you can release the shutter without it, for best results we recommend using flash in this case.

To use flash:

1. Slide the flash switch downward to the  position
 2. When the orange flash-ready lamp glows, frame your subject in the viewfinder and then press the shutter-release button all the way down to take the picture.
- Make sure to turn the flash switch to the off position (slide the switch up) after taking a flash picture, to prevent battery drain.

The flash range is 1.5-4m (4.9-13.1 ft.). For best results, make sure your subject is within this range when taking flash pictures.

- In pictures of people taken with flash, your subjects' eyes may appear red. "Red-eye", as this effect is called, is caused by light from the flash reflected back into the lens from the subject's retinas, and will be more noticeable in some people than in others. To minimize red-eye, we recommend increasing the overall light level as much as possible, and getting as close as possible to the near end of the flash range.

Always use care when taking flash pictures of people or animals, since the flash discharge may be disturbing.

10. REWIND

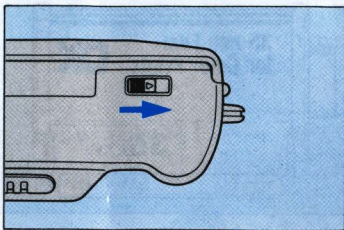

Once the last frame on the roll has been exposed, the motor stops and the shutter locks. To rewind the film, slide and hold the rewind switch until the motor stops and **S** appears in the frame counter. Open the back cover and remove the film.

- Make sure the frame counter shows **S** before opening the back cover.

11. TROUBLESHOOTING

www.butkus.us

Problem	Cause	Solution
Entire picture blurred	Camera Movement	Hold camera steady and release shutter gently
Subject out of focus	Subject too close to camera	Make sure subject is at least 1.5m (4.9 ft.) away from camera
Picture foggy or has blurry areas	Dirty lens	Clean lens as explained in Care and Storage section
Picture too dark or partial picture	Lens or flash obstructed Subject beyond flash range	Keep hands, camera strap and other objects away In low light, make sure subject is within flash range
Shutter cannot be released	End of the roll Lens cover closed Battery exhausted	Rewind film and insert a new roll Open lens cover Replace battery

12. CARE AND STORAGE

- If lens becomes dirty, clean it gently with a lens brush. If necessary, moisten a sheet of lens tissue with one drop of lens-cleaning fluid and gently wipe lens. Never touch lens surface with your fingers.
- Never use alcohol or chemical solvents on the camera body. If it is dirty, wipe it gently with a soft, clean, dry cloth.
- Never subject camera to shock, high heat, or humidity. Be particularly careful not to leave it in the glove compartment or other places in motor vehicles where it may be subjected to high temperatures.
- Using the camera at very low temperatures impairs its performance. In cold weather, carry the camera inside your coat to keep it warm. Do not transfer the camera directly from an extremely cold to warm area, since condensation may form inside and prevent normal operation.
- Do not let the camera get wet. Water seepage could result in costly or irreparable damage to internal parts.

- When not in use, keep the camera in a cool, dry place away from dust and chemicals. Batteries, especially old ones, should be removed if the camera will not be used for more than two weeks. For extended storage we recommend that you place the camera in an airtight container with a drying agent such as silica gel.
- If you have questions about your camera, contact your local camera dealer. For more information write to the Minolta distributor or subsidiary in your area (addresses listed on the back of this manual.)
- Do not attempt to disassemble or repair the camera yourself.
- To assure prompt service, please contact an authorized Minolta Service Center before shipping your camera for repairs.
- This camera's circuitry may switch off, even when a battery with sufficient power is installed. To resume operation, remove the battery and install it again.

13. TECHNICAL DETAILS

Type: Compact 35mm camera with built-in electronic flash.

Lens: 35mm f/4.5

Focusing: Fixed focus; range: 1.5m (4.9 ft.) to infinity

Exposure System: f/8; f/4.5 with flash

Film-speed range: ISO 100 to 400 for DX-coded negative film; ISO 100 set for films without DX coding

Shutter: Behind the lens mechanical type, fixed 1/125 sec. speed

Film transport: Auto advance

Flash system: Built-in flash, manually activated; use-flash lamp; flash-ready lamp

Power: Two 1.5V AA-size alkaline or carbon-zinc cells

Battery performance: Alkaline cells: approx. 55 rolls, carbon-zinc cells: approx. 13 rolls (Based on Minolta's standard test method, using 24-exposure film with flash on 50% of exposures)

Dimensions: 127 X 73 X 49mm
(5 X 2-7/8 X 1-15/16 in.)

Weight: 200g (7-1/16 oz.) without batteries

Specifications subject to change without notice