

**RICOH**

*Owner's Manual*  
*Manual de instrucciones*

**KR-10M**



# ENGLISH

***We are most gratified that you have selected a RICOH camera. Before using your camera, please be sure to read these instructions carefully.***

## LOCATING THE CONTROLS

When reading this manual, refer to “Locating the Controls”

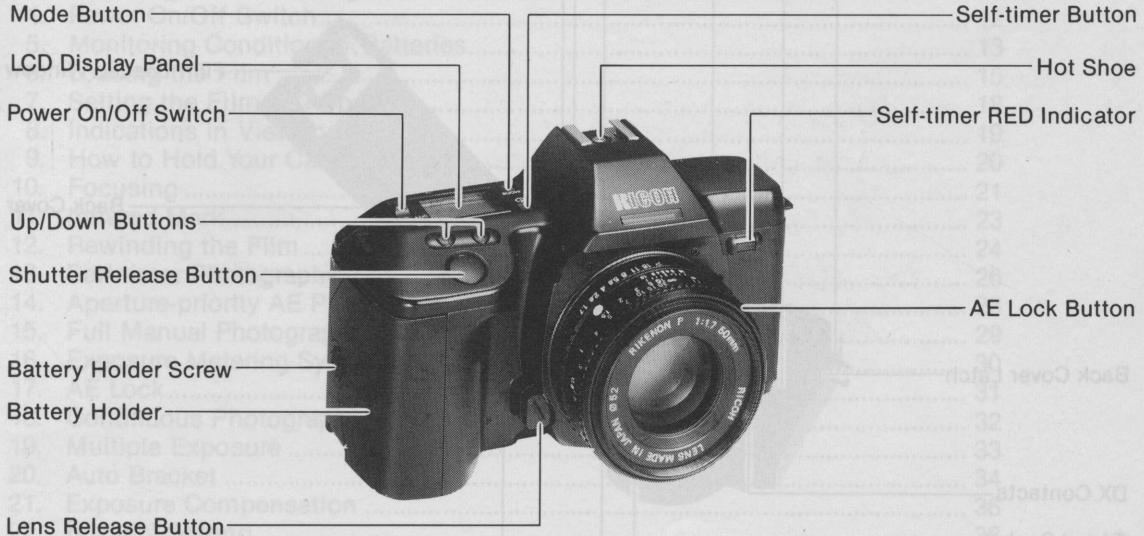



This manual is for reference and historical purposes, all rights reserved.

**This page is copyright© by M. Butkus, NJ.**

This page may not be sold or distributed without the expressed permission of the producer

I have no connection with any camera company

On-line camera manual library

This is the full text and images from the manual. This may take 3 full minutes for the PDF file to download.

**If you find this manual useful, how about a donation of \$3 to: M. Butkus, 29 Lake Ave., High Bridge, NJ 08829-1701 and send your e-mail address so I can thank you. Most other places would charge you \$7.50 for a electronic copy or \$18.00 for a hard to read Xerox copy.**

**This will allow me to continue to buy new manuals and pay their shipping costs.**

**It'll make you feel better, won't it?**

**If you use Pay Pal or wish to use your credit card,  
click on the secure site on my main page.**

PayPal Name Lynn@butkus.org

Venmo @mike-butkus-camera Ph. 2083

[www.PayPal.me/lynnbutkus](http://www.PayPal.me/lynnbutkus)

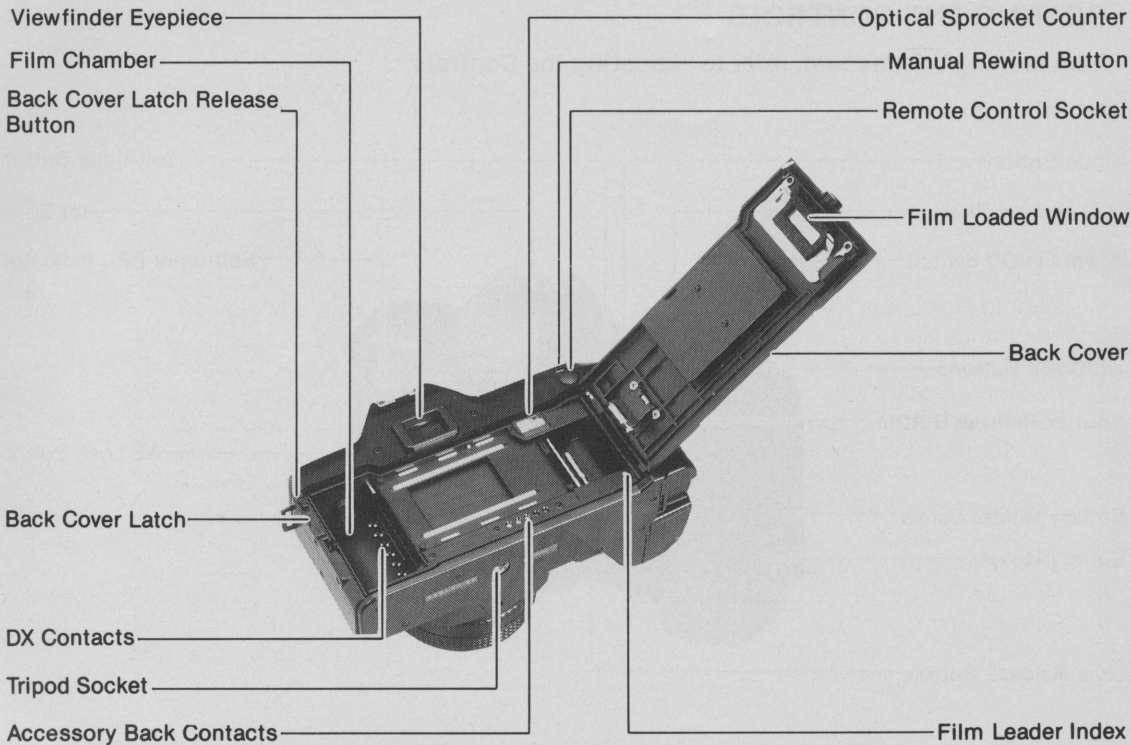

## CONTENTS

1. Attaching the Strap .....	7
2. Inserting Batteries.....	9
3. Mounting and Removing the Lens .....	10
4. Power On/Off Switch.....	12
5. Monitoring Condition of Batteries.....	13
6. Loading the Film .....	15
7. Setting the Film ISO Speed.....	18
8. Indications in Viewfinder.....	19
9. How to Hold Your Camera .....	20
10. Focusing .....	21
11. Infrared Mark.....	23
12. Rewinding the Film .....	24
13. Self-timer Photography .....	26
14. Aperture-priority AE Photography .....	28
15. Full Manual Photography.....	29
16. Exposure Metering Systems.....	30
17. AE Lock.....	31
18. Continuous Photography .....	32
19. Multiple Exposure .....	33
20. Auto Bracket .....	34
21. Exposure Compensation .....	36
22. B (Bulb) Setting .....	38

23.	Flash Photography with SL-303P, SL-200.....	39
24.	Flash Photography with Strobe other than RICOH .....	40
25.	Remote Control Photography .....	41
26.	P-mount Adapter (for Screw Mount Lenses).....	42
27.	Dioptric Lenses .....	43
28.	Data Back 3.....	44
29.	Care of Batteries.....	45
30.	Proper Care of Your Camera .....	46
31.	Major Specifications .....	47

## 1. ATTACHING THE STRAP

1. Remove the Battery Holder by turning the Battery Holder Screw counterclockwise with a coin. **(Fig. 1)**

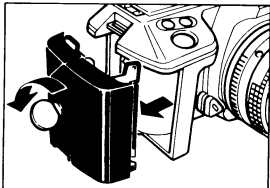

Fig. 1

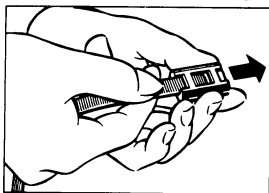

Fig. 2

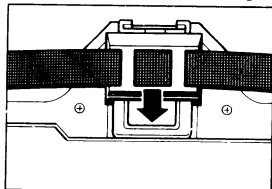

Fig. 3

2. Slip the Viewfinder Cap on to the strap. **(Fig. 2)**  
Slip Cap over Viewfinder. **(Fig. 3)**  
Adjust strap so that it extends about 25 cm (10 inches) from Viewfinder.

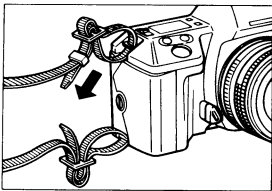

Fig. 4-A

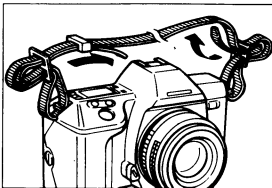

Fig. 4-B

3. Run the strap down through the Upper Strap Lug until it protrudes about 8 cm (3 inches) from the lug. Then feed the end through the Buckle. **(Fig. 4-A.)**
4. Remove Viewfinder Cap off camera, straighten out strap and attach other end to Lower Lug in a similar manner.
5. Adjust the strap length as desired.
6. In case of using both top Lugs, you may be instructed how to fit the strap. **(Fig. 4-B.)**

## 2. INSERTING BATTERIES

1. Insert four fresh AA batteries into the Battery Holder, first checking that the + and – on each battery are lined up correctly according to the polarity diagram inside the Battery Holder. (Fig. 5)

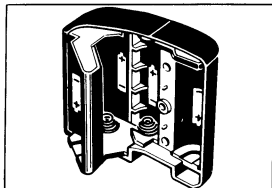

Fig. 5

2. Secure the Battery Holder to the camera body by turning the Battery Holder Screw clockwise with a coin. (Fig. 6)
3. Condition of batteries should be monitored frequently. See Section 5 for details.

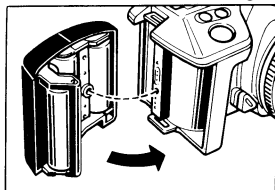

Fig. 6

### Battery Choices:

- ★ Four Penlight (AA) manganese batteries, alkaline batteries or nickel cadmium batteries. (We recommend Alkaline batteries.)

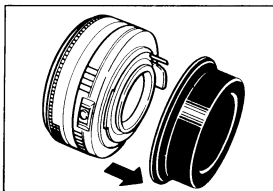

Fig. 7

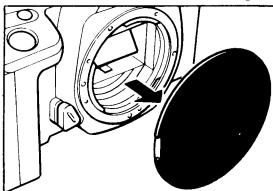

Fig. 8

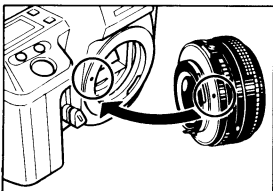

Fig. 9

### 3. MOUNTING AND REMOVING THE LENS

1. Pull off the Back Lens Cap to remove it from the lens. **(Fig. 7)**
2. Pull off the Camera Body Cap. **(Fig. 8)**
3. Align the red dot on the camera with the red dot on the lens and mount the lens on the camera. **(Fig. 9)**

4. Turn the lens in the direction shown by the arrow until it clicks into place. **(Fig. 10)**

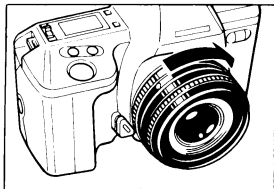

Fig. 10

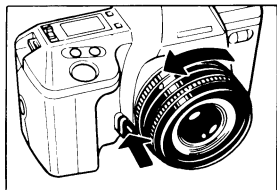

Fig. 11

5. To remove the lens, depress Lens Release Button, then turn the lens in the direction shown by the arrow. **(Fig. 11)**
  - ★ Conventional K mount lenses can be used in Aperture-priority and Manual Modes. Set F-stop number on the lens to "P", the minimum lens aperture will be given.
  - ★ For best results, use Ricoh original equipment lens. Proper performance of camera may not always be assured with other lenses.

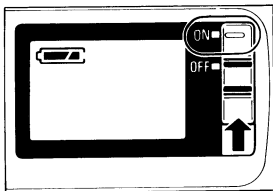



Fig. 12

#### 4. POWER ON/OFF SWITCH

1. Slide the Power On/Off Switch to ON. **(Fig. 12)**
  - ★ The camera is designed to shut off the main power supply automatically to save battery energy when the camera is not in use for about 30 secs. even if the Power On/Off Switch is left ON. This will turn off the top LCD Display, but the information contained in camera memory will be retained. Lightly press the Shutter Release Button to turn on the power and update the LCD Display. For maximum battery life, always turn the Power On/Off Switch to the OFF position when the camera is stored.

## 5. MONITORING CONDITION OF BATTERIES

1. Batteries are in good condition when the  symbol appears on the top LCD Display Panel. **(Fig. 13)**

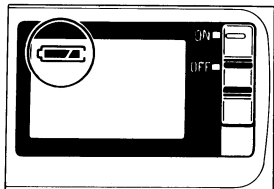



Fig. 13

2. When the batteries are nearly exhausted, the  symbol will be displayed on top LCD. **(Fig. 14)**  
Replace with fresh batteries.

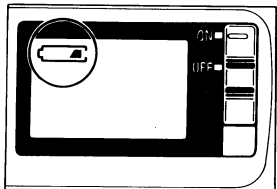



Fig. 14

3. When the batteries are virtually dead, the  symbol will appear in the LCD Display Panel. Replace with new batteries. **(Fig. 15)**

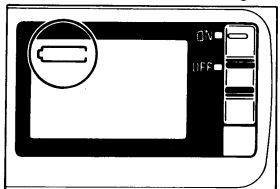



Fig. 15

- ★ If the  symbol lights for about one minute, then disappears, the battery is only capable of retaining camera memory. However, do not remove old batteries until you are ready to replace them with fresh ones.  
The memory of the photography mode and exposure counter number will be retained for about 30 minutes without batteries. If you replace with new batteries within that 30 minutes, the display of the photography mode left in the camera memory will again appear in LCD Display Panel.
- ★ Cold temperatures will reduce battery efficiency. In freezing weather, the symbol may turn off and only the  symbol may show on the LCD Display Panel. If you are taking pictures in cold weather, keep the batteries warm and insert them just before shooting. (If batteries are removed for more than 30 minutes, counter may reset to "0". Film will automatically advance 3 frames when batteries are reinserted.)

## 6. LOADING THE FILM

Always avoid direct sunlight when loading the film.

1. Depress the Back Cover Lock Release Button and slide the Back Cover Latch down. **(Fig. 16)**

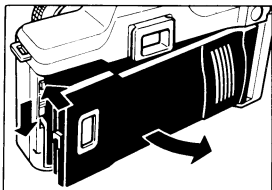

Fig. 16

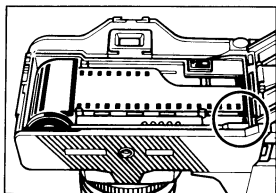

Fig. 17

2. Load the Film Cassette into the Film Chamber and pull out enough film leader to extend just beyond the green mark, against the Take-up Spool. **(Fig. 17)**

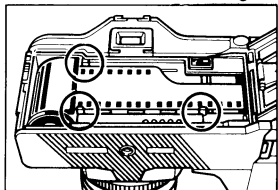

Fig. 18

3. Make sure that the film is within the Film Guides, and that the upper sprocket edge is under the Guide Plate. **(Fig. 18)**

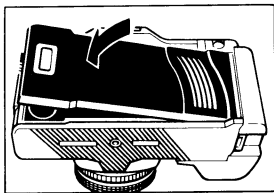

Fig. 19

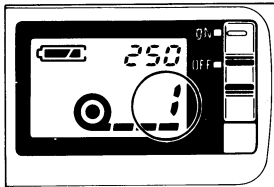

Fig. 20

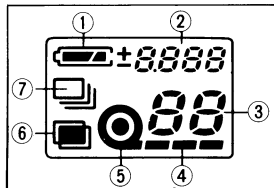

Fig. 21

4. Close the Back Cover so that the Back Cover Latch snaps shut. **(Fig. 19)**

The film will now automatically advance until number “1” appears on the top LCD Display Panel. **(Fig. 20)**

5. As soon as you close the Back Cover, the LCD Display Panel will show the following signs **(Fig. 21)**:

- ① Battery Indicator
- ② Shutter SPEED
- ③ Exposure Counter
- ④ Film advance symbols (these symbols will flash in sequence toward the right to tell you the film is winding)
- ⑤ Film Cassette loaded symbol
- ⑥ Multiple Exposure Mode (If activated.)
- ⑦ Continuous Photography Mode (If activated.)

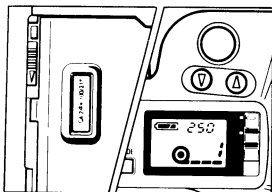

Fig. 22

- ★ LCD display data can be verified by checking the information visible through Film Loaded Window on camera back. **(Fig. 22)**
6. If the film has not advanced correctly or was not taken up onto the Film Take-up Spool, the Film Cassette loaded symbol will blink until the film has been loaded correctly. Reload the film by repeating steps 1—5 shown above. If Non-DX films are loaded in the camera, no LCD warnings will be observed. (The film ISO speeds must also be set manually. See next section.)

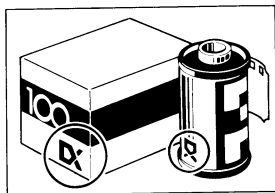

Fig. 23

## 7. SETTING THE FILM ISO SPEED

DX coded films are provided with black-and-silver patterns corresponding to film speed and number of exposure on roll. The camera reads this pattern and automatically sets itself for DX films with speeds ranging from ISO 25 to 5000. (Fig. 23)

### DX films

- ★ For advanced applications, you may wish raise or lower the ISO speed of a DX coded film. This may be done by using the Exposure Compensation Adjustment Button. See Section 21 for details.

### Non-DX films

Using Non-DX film, film speed will be set ISO 100 automatically. If you want to use other film speed, you can do it by selecting Exposure Compensation from ISO-6 to ISO 1600.

Exposure Compensation	+4	+3	+2	+1	0	-1	-2	-3	-4
Film Speed	6	12	25	50	100	200	400	800	1600

## 8. INDICATIONS IN VIEWFINDER (Fig. 24)

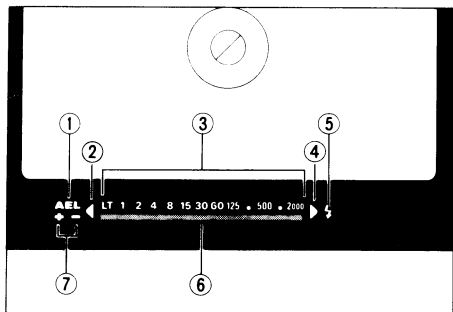

Fig. 24

- ① Blinking AE Lock Indicator
- ② Blinking Underexposure Indicator
- ③ Shutter Speed Scale
- ④ Blinking Overexposure Indicator
- ⑤ Flash Ready Indicator LEDs
- ⑥ Shutter Speed Indicator
- ⑦ Blinking Exposure Compensation Indicator

### ★ Viewfinder illumination

An auxiliary light turns on automatically when finder LCD is dark and difficult to see.



Fig. 25



Fig. 26

## 9. HOW TO HOLD YOUR CAMERA (FOR SHARPER PICTURES)

1. Lightly put your right-hand forefinger on the Shutter Release Button while holding the camera body with other fingers.
  2. Make your right arm comfortable, but keep it as close to your body as possible.
  3. Cradle your camera and lens in the palm of your left hand, holding it so that the Focusing Ring can be easily turned with your fingers.
  4. Brace your left elbow against your body and hold the camera comfortably against your face. Look through the Viewfinder to compose your picture.
- ★ It is important to practice correct shooting position to avoid blurred or tilted pictures. (Figs. 25, 26)

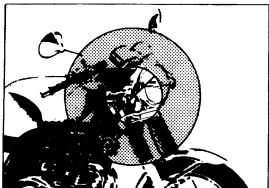

Fig. 27-A

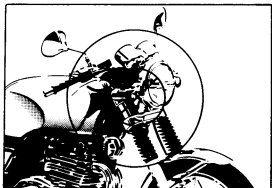

Fig. 27-B

## 10. FOCUSING

Look through the Viewfinder and turn the Focusing Ring until you obtain the sharpest possible image. (Figs. 27-A, 27-B)

### 1. Split image focusing spot:

When both images in the split-image spot form a single, clear image, the subject is in focus.

### 2. Microprism focusing collar:

When the subject loses its shimmering appearance, the subject is in focus.

### 3. Matte screen focusing field:

When the subject loses its blurred appearance, the subject is in focus.

- ★ Long focal length lenses and/or lenses with small maximum apertures may black-out part of the central focusing aids. When using these lenses, you must rely on the matte screen for accurate focusing.

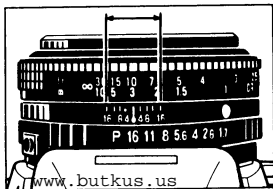

Fig. 28

**On many lenses, your depth-of-field can be checked in the following way:**

1. Focus the lens on the subject.
2. The main indicator line opposite the lens focusing scale will show the actual distance to the subject.
3. A pair (or pairs) of lines alongside the main indicator will now show the range of subject sharpness on either side of the subject that will also be in acceptable focus at one or more aperture (F/number) settings.

For example, if you are using a 50 mm normal lens, set to  $f/16$  and focused to 3.0 m (10 ft.), the two depth-of-field indicators (for  $f/16$ ) will show a range of sharp focus from about 1.8 m (6 ft.) to 7.6 m (25 ft.). Subjects within this range will be in good focus. (Fig. 28)

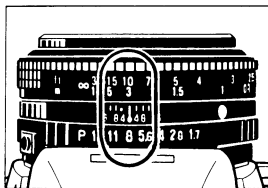

Fig. 29

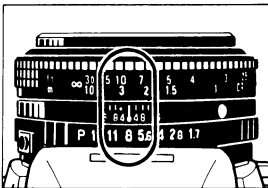

Fig. 30

## 11. INFRARED MARK

Always re-adjust your focus to the infrared focusing mark when using infrared films and an R60 (or equivalent) filter. This is necessary because the image forming, invisible IR rays have longer wave lengths than the visible light rays you see and focus with, and the camera lens focuses them slightly further back inside the camera. Therefore, visual focusing can not be accurate without some compensation.

1. Attach the R60 filter and visually focus on the subject. Read the indicated distance off the lens barrel. **(Fig. 29)**
  2. Shift that distance setting over to the red infrared index mark. **(Fig. 30)**
- ★ Many lenses do not provide separate IR indicator, in which case some “Bracketing” of distance settings may be necessary.
3. Set the exposure in accordance with operating instructions for the film.
- ★ Always refer to film instructions for special precautions and procedures when any infrared film is used.

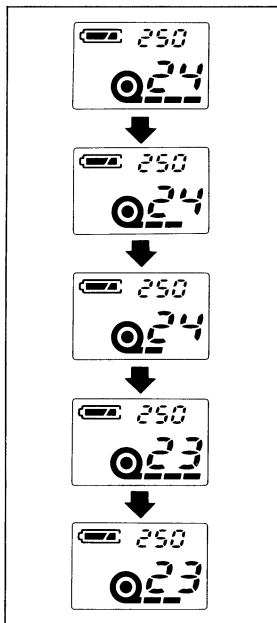

Fig. 31

## 12. REWINDING THE FILM

- DX coded films will rewind automatically when you reach the end of the roll.
- ★ Film rewinding is indicated by a series of three dashes flashing in sequence from right to left, while the Exposure counter is counting down. (Fig. 31)

2. When the film is fully rewound, the motor stops automatically and "E" appears on the LCD Display Panel. **(Fig. 32)** You can now open the Back Cover to unload the film.  
★ The Shutter Release is locked when "E" is displayed.
3. If you wish to rewind the film before the end of roll is reached, push the recessed Manual Rewind Button on the back of the camera with a pen, etc. for about 2 seconds. **(Fig. 33)**

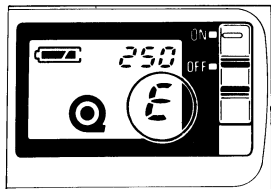

Fig. 32

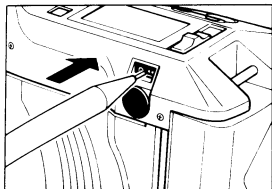

Fig. 33

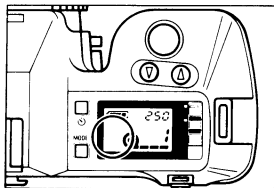

Fig. 34

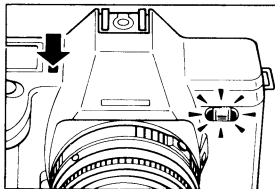

Fig. 35

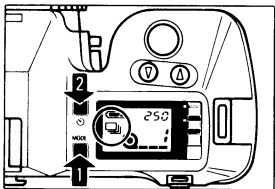

Fig. 36

### 13. SELF-TIMER PHOTOGRAPHY

The Self-timer is used to include yourself in your pictures and normally provides a delay of 10 seconds.

1. Switch to single exposure mode. **(Fig. 34)**
  - ★ If full display information is not showing, lightly touch the Shutter Release to make the information reappear.
  
2. Press the Self-timer Button. The Self-timer RED Indicator lamp will blink. **(Fig. 35)**
  
3. You can use the Self-timer in Continuous Mode. It will allow taking two pictures in a row. **(Fig. 36)**
  
4. To cancel the Self-timer after it has been started, press the Self-timer Button again or turn the Power Switch OFF.

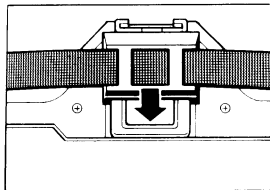

Fig. 37

- ★ When using the Self-timer in all modes other than manual, always use the Viewfinder Cap attached to the strap to cover the Viewfinder Eyepiece to avoid incorrect exposure due to stray light entering the Viewfinder Eyepiece. **(Fig. 37)**

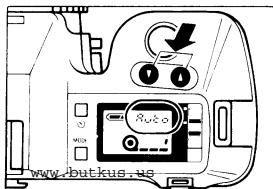

Fig. 38

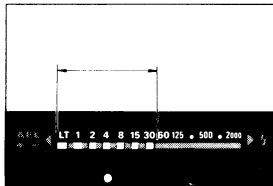

Fig. 39

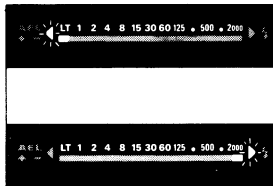

Fig. 40

## 14. APERTURE-PRIORITY AE (AUTO-EXPOSURE) PHOTOGRAPHY

In aperture-priority AE photography, the camera automatically sets correct shutter speeds according to your pre-selected F-stop number and the brightness of your subjects. This is suitable for photography taking advantage of specific depth-of-field requirements as in portraits or scenic pictures.

1. Push Up-Down Button till **AUTO** appears in LCD display. (Fig. 38)
2. Turn the F-stop Ring to set the desired F-stop number.
  - ★ When the Shutter Speed Indicator in the Viewfinder is in LT to 30 (1/30 sec.) range, the shutter speed is too slow to hand-hold. (Fig. 39)

Either select a new F-stop or mount the camera on a tripod or other suitable support.

- ★ When an overexposure symbol ( ► ) or underexposure symbol ( ◀ ) appears in the Viewfinder, the camera is unable to provide the proper shutter speed for correct exposure. (Fig. 40)

Adjust the F-stop Ring (to change the F-stop number) until you are able to obtain an acceptable exposure within the available shutter speed range and extinguish the over/underexposure symbol.

## 15. FULL MANUAL PHOTOGRAPHY

You may manually select the shutter and the F-stop number for unusual or creative picture taking situations.

1. Press and hold the Up or Down Button for about one second until the desired shutter speed is indicated on the LCD Panel.
2. Set the shutter to the desired speed using the Up or Down Button and information provided on LCD Display. (**Fig. 41**) Your pre-selected shutter speed will be shown by the single steady indicator on the Viewfinder LCD Display. A second shutter speed indicator may blink to indicate the camera meters suggested speed at a given f-stop. (**Fig. 42**)
  - ★ The shutter speed setting will also be displayed in the Top LCD.
3. Turn the F-stop Ring until your shutter speed indicator and the camera meter's blinking indicator (showing suggested exposure) overlap each other. (**Fig. 43**) This confirms that correct exposure is set.

— or —

4. Manually adjust the shutter speed to move the setting indicator towards the blinking indicator. (**Fig. 43**)

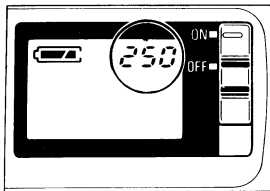

Fig. 41

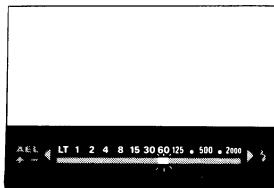

Fig. 42

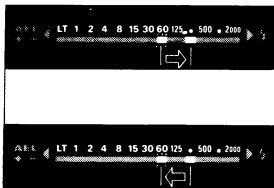

Fig. 43

## 16. EXPOSURE METERING SYSTEMS

The camera is designed to make **center-weighted average exposure readings**.

Lighting situations vary and the camera provides you with the means to master them. Under normal conditions, centerweighted average metering is most applicable and determines an ideal balance between subject and background lighting.

- ★ This is a convenient metering system for general photography under normal shooting conditions. It measures the viewing area, emphasizing the center portion where the subject is likely to be, with diminishing sensitivity toward the edges.

## 17. AE LOCK

When back light or spot light is given to the subject being metered in AE photography and contrast is excessive between the background and the subject, under or over exposed pictures may result. Use the AE lock to remember, or lock into the camera's electronic memory a close-up reading of the subject.

1. Bring the camera close to subject to the point that exposure will not be affected by the background.

2. Press the AE Lock Button once to memorize the exposure.

**(Fig. 44)**

A flickering AEL is now displayed on the Viewfinder LCD.

**(Fig. 45)**

3. AE lock is automatically cancelled after the Shutter Release Button is pressed for the exposure.

★ To cancel AE lock without taking a picture press AE Button a second time.

★ For a continuous exposure series under similar conditions all requiring the use of AE lock, you may wish to adjust your exposure using the exposure compensation feature instead.

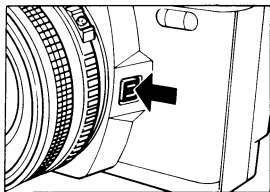

Fig. 44

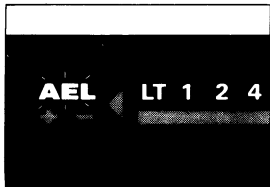

Fig. 45

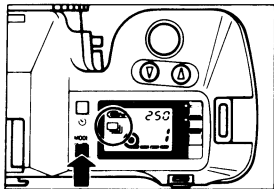



Fig. 46

## 18. CONTINUOUS PHOTOGRAPHY

Push the Mode Button until  mark appears in the LCD display (Fig. 46),

1. It is now possible to take continuous pictures suitable for fast moving objects.
2. Selecting continuous mode and pushing Self-timer Button will allow you to take two frame pictures in a row.

## 19. MULTIPLE EXPOSURE

1. If you want to take two or more pictures on a frame, push Mode Button till you see  mark in the LCD display. (Fig. 47) The shutter may be released one or more times without advancing the film. (See Example 1.)
2. You can cancel this mode by shutting off the Main Switch or pressing the Mode Button.

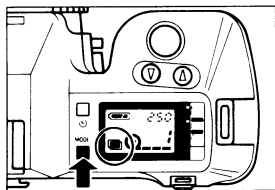
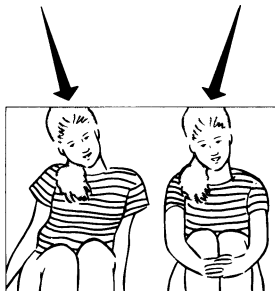

Fig. 47



Example 1

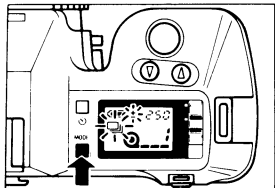
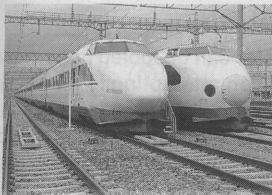

Fig. 48

## 20. AUTO BRACKET

1. When you push the Mode Button, you will see the blinking camera icon and  $\pm$  mark at the same time (**Fig. 48**), then you enter the Auto Bracket Mode. It means that you can take three frames in a row by one shutter release. Each of the three frames will have a different EV (0, +0.5, -0.5 stop).  
**(See Example 1—3.)**
2. When the Exposure compensation mode or AE lock mode is selected, exposure adjustments will be made by  $\pm 0.5\text{EV}$  toward the setting which you already selected.



Example 1

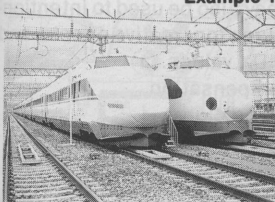

Example 2

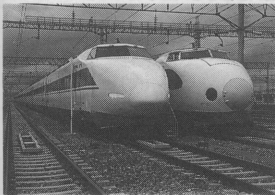

Example 3

3. If using a dedicated flash which is fully charged, the Auto Bracket Mode will not work.
4. When you use Reversal film, you will see the maximum effect of this mode.



**Example 1**



**Example 2**

## 21. EXPOSURE COMPENSATION

Any camera's center-weighted meter can be fooled under very extreme lighting conditions, or when attempting to read very light (e. g. snow or beach scenes) or very dark (night scene) subjects. Also, when back or spot lit subjects are being metered in AE photography and contrast is excessive between the background and the subject, under or over exposed pictures usually result. Exposure compensation may also be used to intentionally take over/underexposed pictures for creative effects, and to adjust ISO speeds away from DX values.

**Example 1:** Without exposure compensation

**Example 2:** With exposure compensation

### Exposure adjustment examples:

SUBJECT	EXPOSURE ADJUSTMENT
Figures in back light Scenery with much sky	+ 4 to + 1
Figures with snow, sand or sea in the background	+ 1
Figures in spot light (on stage etc.)	- 4 to - 1

1. Press Mode Button to display  $\pm$  mark on the LCD. **(Fig. 49)**

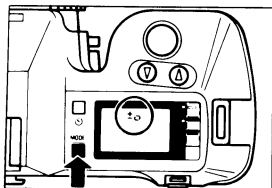

Fig. 49

2. Press the Up or Down Button until the desired amount and direction of the compensation appears on the LCD. Adjustments may be made up to  $+/- 4$  EV (stops) in  $1/3$  EV increments. **(Fig. 50)**

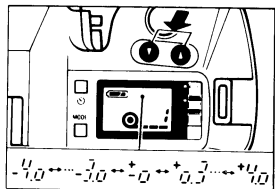

Fig. 50

- ★ Be sure to set it back to the "0" position after use.
- ★ When the exposure compensation is set at positions other than 0, the  $+/-$  symbols are displayed on both LCD's. **(Fig. 51)**
- ★ Remember that you must increase exposures to keep light subjects light, and decrease exposures to keep dark subjects dark.

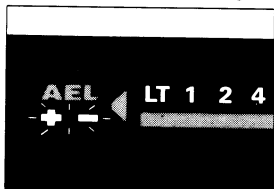

Fig. 51

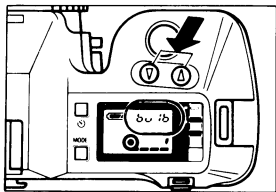

Fig. 52

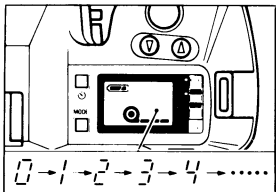

Fig. 53

## 22. B (BULB) SETTING

The B (Bulb) setting is used for shooting night scenes or other long exposure times.

1. Set the shutter speed to BULB by pressing the Up or Down Button. (Fig. 52)
2. When the Shutter Release Button is pressed, the shutter is kept open as long as the button remains depressed.
3. A digital count of the exposure time will be shown up to 99 seconds on the Top LCD as long as the shutter release is held down. (Fig. 53)
  - ★ Use a tripod and Ricoh Electronic Cable Release for bulb photography to prevent the unintentional movement of camera. Before you plug the electronic cable release into the camera, turn the Power Switch off.
  - ★ A long exposure may be terminated anytime during the exposure by pushing the camera power switch to OFF.

## 23. FLASH PHOTOGRAPHY WITH SL-303P, SL-200

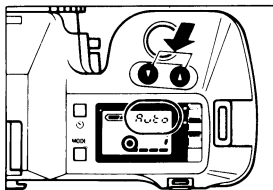

Fig. 54

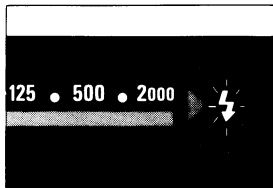

Fig. 55

1. When you add any of the above RICOH dedicated flash systems, you can enjoy more exciting applications.
2. Set flash unit to "A", and camera mode to "AUTO" by pushing Up-Down Button (Fig. 54), then F-stop of lens is set to F5.6.
3. For Manual Flash Photography, slide the switch lever of flash unit to "M", and select the shutter speed from L16 to 60 (If shutter speed is shown between 1/125 – 1/2000, in that case shutter speed will be set to 1/100 automatically). Then you may chose F-stop number whichever you want according to the formula below.

$$F\text{-stop} = \frac{\text{G. No.}}{\text{Distance (m)}} = \frac{\text{G. No. (Ft.)}}{\text{Distance (Ft.)}}$$

4. When flash unit is fully charged, Flash-ready Lamp on the flash unit lights, also ⚡ mark in the viewfinder lights. (Fig. 55)  
Now you are ready to take a flash photograph.

## **24. FLASH PHOTOGRAPHY WITH STROBE OTHER THAN RICOH**

1. When you want to use the flash in “AUTO-mode”, set shutter speed on camera to 1/60, the lens to specific F-stop number instructed by strobe you have.
2. If you want to take flash photography manually, refer to step 3 of FLASH PHOTOGRAPHY WITH SL-303P, SL-200.

## 25. REMOTE CONTROL PHOTOGRAPHY

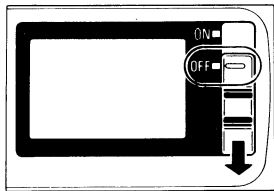

Fig. 56

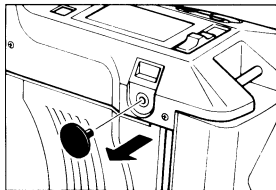

Fig. 57

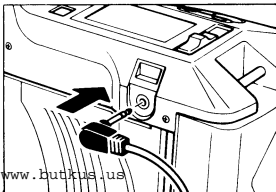

Fig. 58

1. Slide Power On/Off Switch to OFF position. (Fig. 56)
2. Remove Remote Control Cap on the camera. (Fig. 57)
3. Insert the Remote Control Plug to the Socket on the camera. (Fig. 58)
4. Turn Camera Power On/Off Switch back to ON position.
5. Press the Shutter Release Button.

## 26. P-MOUNT (SCREW) ADAPTER

Conventional P-mount lenses (screw mount lens) can be used on the camera by using an optional P-mount Adapter. General photography is available but operating conditions are somewhat limited.

- ★ Any automatic diaphragm will not function. (Some lenses may remain wide open, while others remain stopped down, depending on how they were designed.)

### **Inserting and removing the adapter**

1. Align the red dots and carefully fit the adapter into the body mount.
  2. Use a ball-point pen, etc. to turn it clockwise until it locks in place.
  3. To remove the Adapter use a ball-point pen, etc. to press the spring inwards and turn the P-mount Adapter counterclockwise to the limit. Lift it out carefully.
- ★ Some screw mount lenses cannot be mounted on the camera.

Testing the fit of any lens you purchase for this camera is strongly recommended.

## 27. DIOPTRIC LENSES

The viewfinder eyepiece has a built-in  $-1$  correction (suitable for most normal vision).

If your vision requires correction and an optional dioptic lens is fitted, you do not have to wear eye-glasses when taking pictures. Slip the lens in the groove in the finder eyepiece.

### **Dioptic lenses are available in 7 types:**

$-4$ ,  $-3$ ,  $-2$ ,  $-1$ ,  $+1$ ,  $+2$  and  $+3$  (Diopters)

**Note:** Some forms of astigmatism etc. may make dioptic eyepiece correction impossible. Please check with your vision specialist for a recommendation based on your prescription.



## 28. DATA BACK 3

When the Back Cover of the camera is replaced by the Data Back 3, "year, month and date", or "hour, minute" can be printed on your film.

The automatic dating mechanism is incorporated into the Data Back 3. Once the date is set, no adjustment is necessary until 2019 (except when the battery is removed), because leap years and months with 31 or less days are automatically adjusted. When the Camera Power On/Off Switch is turned OFF, it can be used as digital watch.

2. Use a non-flammable, etc. to turn it clockwise until it locks in place.
  3. To remove the Adapter use a ball-point pen, etc. to press the spring inwards and turn the P-mount Adapter counterclockwise to the limit. Lift it out carefully.
- ★ Some screw mount lenses cannot be mounted on the camera.  
Testing the fit of any lens you purchase for this camera is strongly recommended.

## **29. CARE OF BATTERIES**

- 1. Before installing, be sure to clean all moisture and skin oil off both battery contact surfaces in order to avoid future problems of corrosion and poor electrical contact.**
- 2. Remove batteries when the camera is not used for a long period of time.**
  - ★ Removal of the battery case may result in a loss of camera memory. The film may also advance two or three frames when the batteries are replaced. (Also see Section 5.)**
  - ★ Dispose of batteries properly. Do not throw them into fire or expose to high temperature.**

### **30. PROPER CARE OF YOUR CAMERA**

1. Do not touch lens or mirror surfaces with your fingers to clean them. Blow dust away with a blower or wipe gently with soft cloth. If you must clean the lens surface use only 1 drop of lens cleaning fluid on a camera lens tissue.
2. Excessive shock and humidity, or salt may make any camera malfunction. When you use the camera at the beach, in a corrosive atmosphere, or in a place where chemicals are used, carefully wipe it clean.
3. Do not expose camera and film to temperature extremes.
4. Do not leave your camera in a car at the beach, in the desert, or in other high temperature conditions.
5. When using a tripod, do not try to force a long screw into the socket. The screw length should not extend more than 5.7 mm (1/4 inch).
6. Do not store the camera near a television, radio or other strong magnetic source.
7. Store camera in a humidity and dust free place.

## 31. MAJOR SPECIFICATIONS

<b>Type:</b>	35mm SLR with focal plane shutter and automatic electronic exposure control
<b>Photographic Modes:</b>	Aperture-priority automatic exposure mode
<b>Film Format:</b>	35mm film, 24 x 36mm
<b>Lens Mount:</b>	Ricoh system R-K mount
<b>Shutter:</b>	Electrically controlled, vertically moving focal plane shutter Automatic: 32 sec. to 1/2000 sec. Manual: 16 sec. to 1/2000 sec.
<b>Self-Timer:</b>	Operating time: 10 seconds
<b>Viewfinder:</b>	Field of view covers 91% horizontally and vertically Magnification: 0.80X (with 50mm F1.4 standard lens) Viewfinder Display: AE lock, exposure compensation, shutter speed indicator, long time exposure, overexposure mark, flash ready indicator
<b>Focusing:</b>	Diagonal split-image spot in microprism band; plus full ground glass field
<b>Exposure Metering System:</b>	Center-weighted average metering

<b>Exposure Coupling Range:</b>	EV 0 -18 (with ISO 100 film, 50mm F1.4 standard lens)
<b>Flash Terminal:</b>	X synchro contact on the hot shoe
<b>Flash Modes:</b>	1. Aperture-priority flash AE 2. Manual Flash
<b>Exposure Compensation:</b>	Exposure adjustment system (+4 to -4 in 1/3 EV increments)
<b>Film Loading:</b>	Ricoh Auto-Load system. Automatic 1st frame setting
<b>Film Advance:</b>	Automatic with a built-in motor. Two selectable modes; S (single) and C (continuous approx. 3 fps)
<b>Film Rewind:</b>	Automatic reverse at the end of film. Manual rewind is possible
<b>Remote Control:</b>	Electronic remote control socket is provided
<b>Back Cover:</b>	Removable

<b>LCD Display:</b>	Film loaded, film advancing, film taken up onto film take-up spool, exposure counter, film rewinding, film rewind completed, exposure compensation symbol, shutter speed, selected exposure compensation, film advance mode (S/C), battery indication (good, alarm, low and low for flash) multi exposure, time indicator of bulb-mode
<b>Power Source:</b>	Four AA batteries.
<b>Dimensions:</b>	151 (W) × 91 (H) × 51 (D) mm (5.9" × 3.6" × 2.0") (with AA battery holder)
<b>Weight:</b>	510g (18.0 oz) (body only with AA battery holder)

Specifications and appearance of this camera are subject to change without notice